



# Assembling Your SawStop Contractor Saw

Before assembling your saw, make sure that you have all the components identified on pages 14 and 15 in the Owner's Manual, including hardware pack #1 and hardware pack #2. Call the SawStop Service Department at 503-582-9934 if any components are missing. Hardware pack #2 includes some of the tools needed to assemble the saw. You will also need the following additional tools:

1. an 8 mm socket
2. a 10 mm wrench
3. two 13 mm wrenches
4. a level or straight edge

## Assembling the Stand

• Locate the stand components labeled (A) through (F) and hardware pack #1. All of the hardware needed to assemble the stand is located in the area with the blue background on hardware pack #1. In order to easily identify the hardware used in each of the following steps, the different pieces of hardware are numbered on the hardware pack and on these assembly instructions.

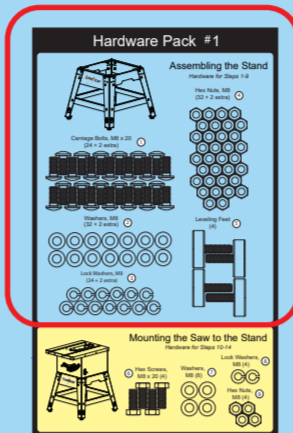

### 1

• Assemble the front of the stand by attaching two of the legs marked (A) to the front panel marked (B). Make sure that the legs are in front of the front panel. Bumps on the legs fit into holes in the front panel to align the legs. Attach the legs to the front panel using four M8 x 20 carriage bolts (1), four M8 washers (2), four M8 lock washers (3), and four M8 hex nuts (4). Do not fully tighten the nuts at this time. Leaving the nuts loose will make it easier to align holes as you assemble the rest of the stand.

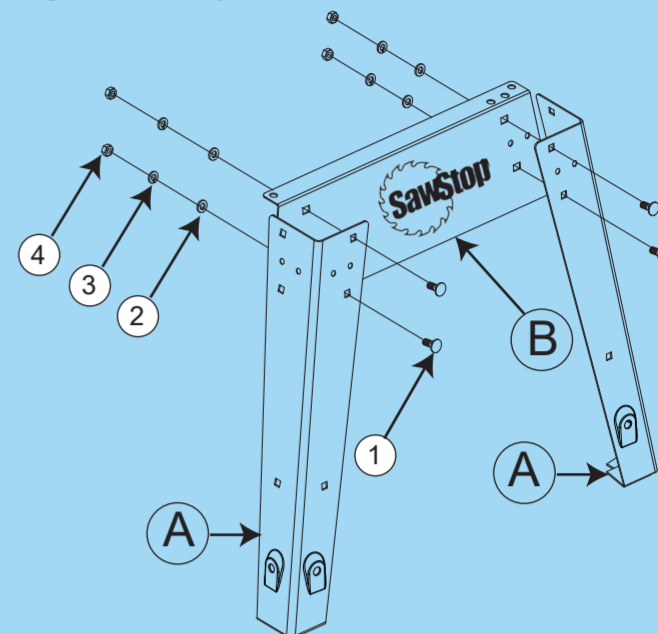

### 2

• Assemble the rear of the stand by attaching the remaining two legs marked (A) to the rear panel marked (C). Make sure that the legs are in front of the rear panel. Bumps on the legs fit into holes in the rear panel to align the legs. Attach the legs to the rear panel using four M8 x 20 carriage bolts (1), four M8 washers (2), four M8 lock washers (3), and four M8 hex nuts (4). Do not fully tighten the nuts at this time.

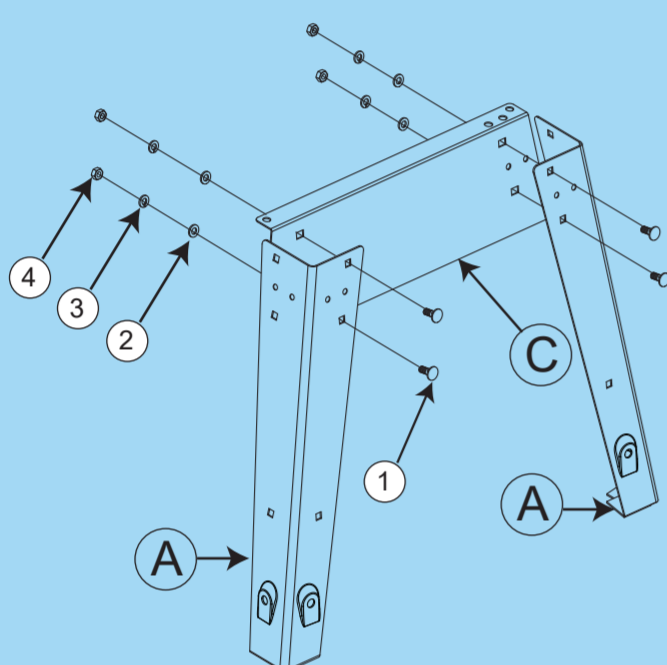

### 3

• Attach one of the side panels marked (D) between the front and rear portions of the stand. Make sure the legs are in front of the side panel and that the side panel is under the top flanges of the front and rear panels. Bumps on the legs fit into holes in the side panel to align the legs. Use four M8 x 20 carriage bolts (1), four M8 washers (2), four M8 lock washers (3), and four M8 hex nuts (4) to attach the side panel to the front and rear portions. Do not fully tighten the nuts.

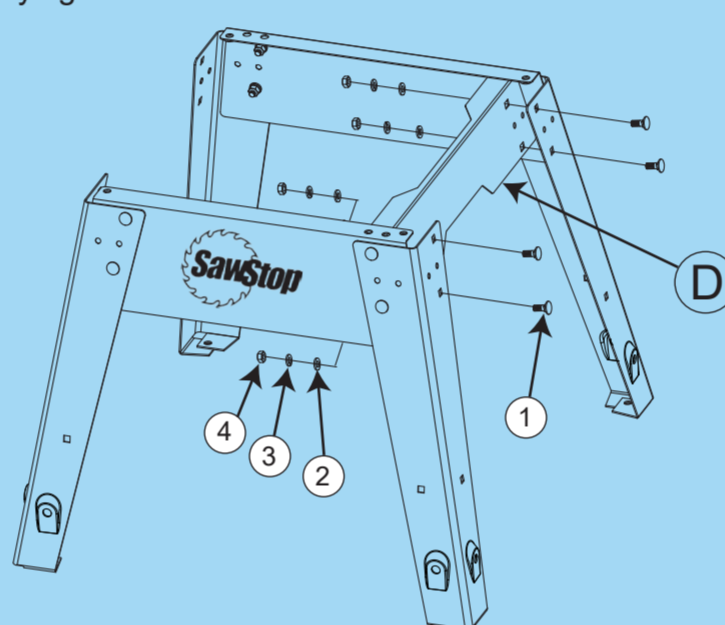

### 4

• Repeat the prior step to attach the remaining side panel marked (D) to the opposite side of the stand.

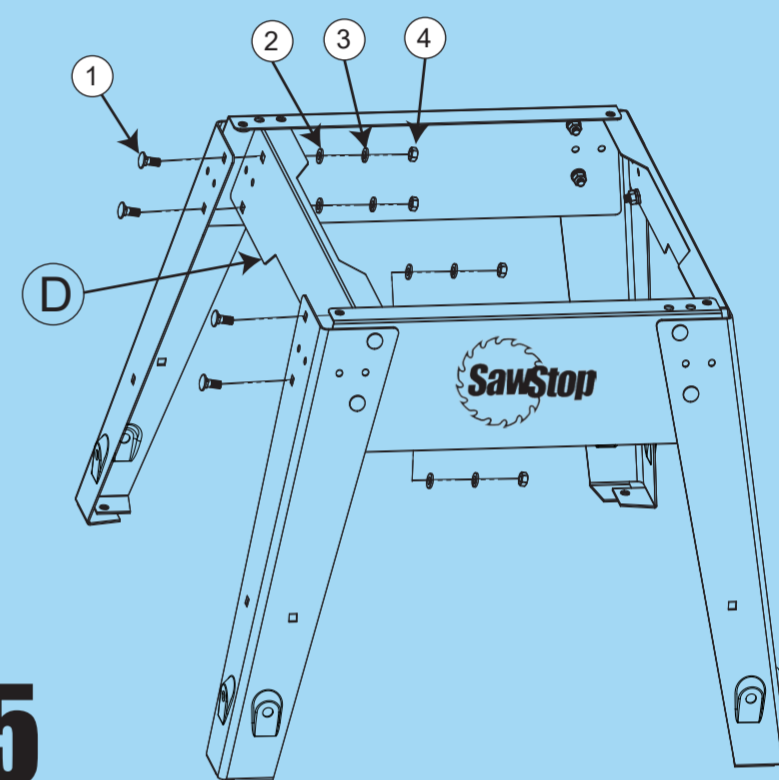

### 5

• Attach one of the short brackets marked (E) between the two front legs. Make sure the legs are in front of the bracket. Use two M8 x 20 carriage bolts (1), two M8 washers (2), two M8 lock washers (3), and two M8 hex nuts (4). Do not fully tighten the nuts. Repeat this process to attach the remaining short bracket (E) between the rear legs.

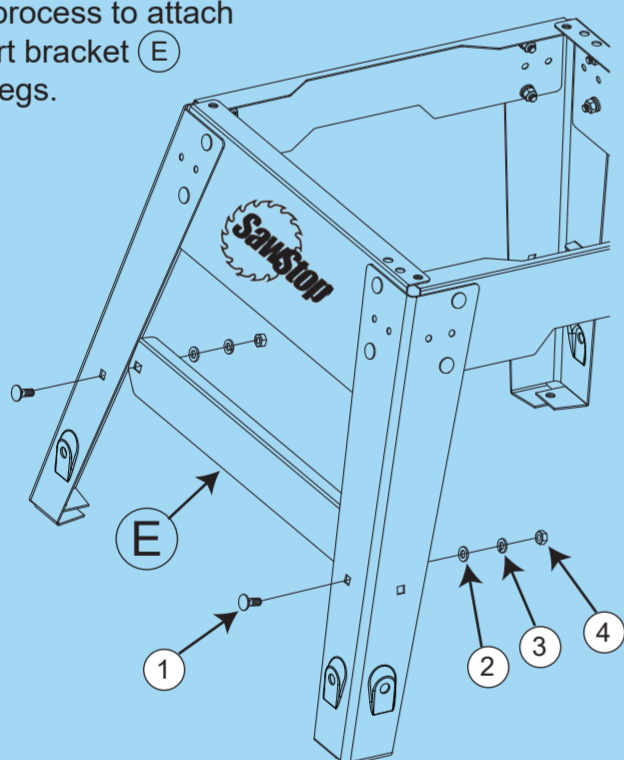

### 6

• Attach one long bracket marked (F) between the legs on the right side of the stand. Make sure the legs are in front of the brackets. Use two M8 x 20 carriage bolts (1), two M8 washers (2), two M8 lock washers (3), and two M8 hex nuts (4) to attach the long bracket. Do not fully tighten the nuts. Repeat this process to attach the remaining long bracket (F) between the legs on the left side of the stand.

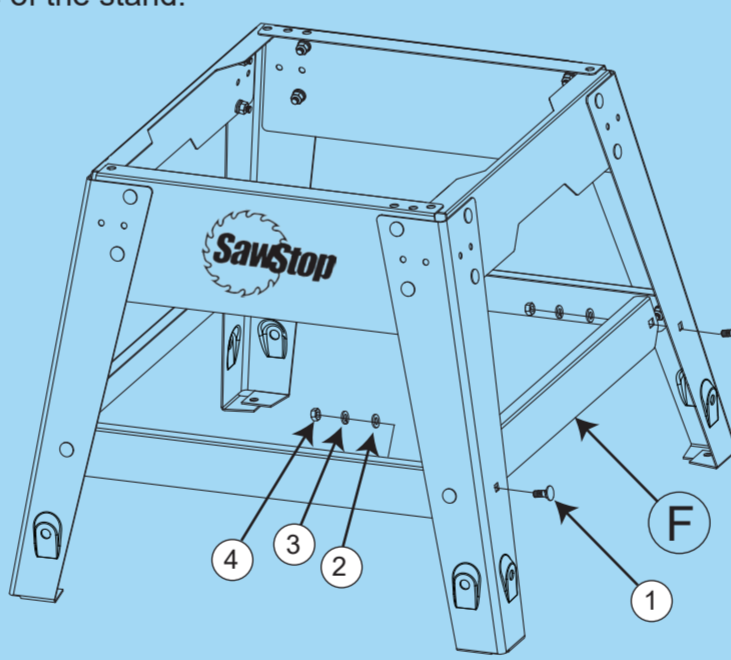

### 7

• The front, rear and side panels have flanges that overlap to define mounting holes through which you will bolt the saw to the stand. There is one hole in each corner of the stand. Adjust the panels until the holes align and then tighten all of the nuts in the stand using a 13 mm wrench.

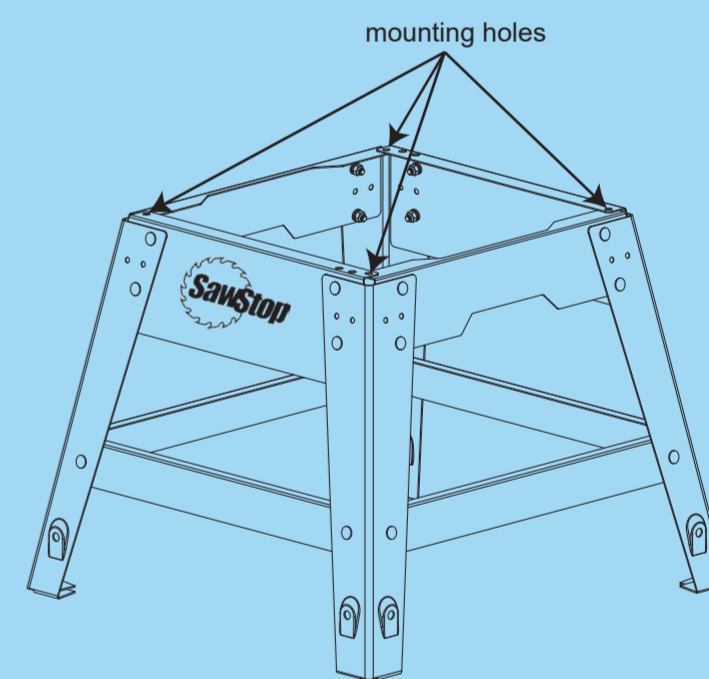

### 8

• Attach a foot (5) to the bottom of each leg by threading an M8 hex nut (4) on each foot and then placing an M8 washer (2) over the nut. Insert a foot into the hole at the base of each leg and then place a second M8 washer (2) and thread a second M8 hex nut (4) onto each foot. Do not fully tighten the nuts. The stand is now fully assembled.

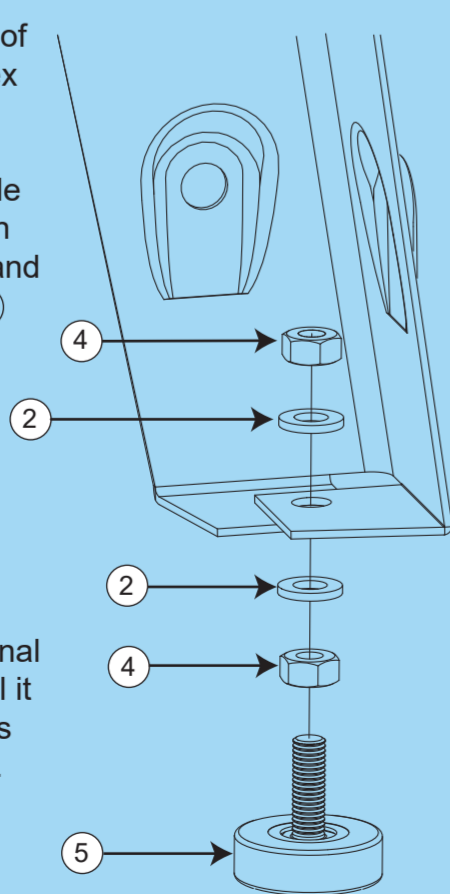

Note: If you purchased an optional mobile base for your saw, install it now by following the instructions that came with the mobile base.

### 9

## Mounting the Saw to the Stand

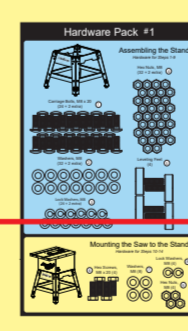
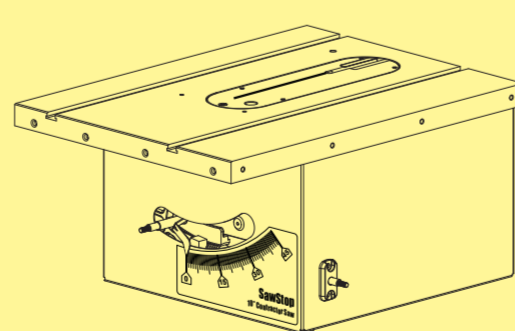

### 10

• Remove the saw from the box and locate the mounting hardware. All of the hardware needed to mount the saw to the stand is located in the area with the yellow background on hardware pack #1.

• With the help of an assistant, pick up the saw and carefully set it on the assembled stand with the front of the saw above the front panel of the stand. Align the mounting holes in the bottom corners of the saw with the mounting holes in the top corners of the stand. While moving the saw do not set it down in the upright position on a solid surface because the dust shroud can be damaged. **Warning!** The saw weighs approximately 140 pounds. Be careful and use proper lifting technique to avoid injury.

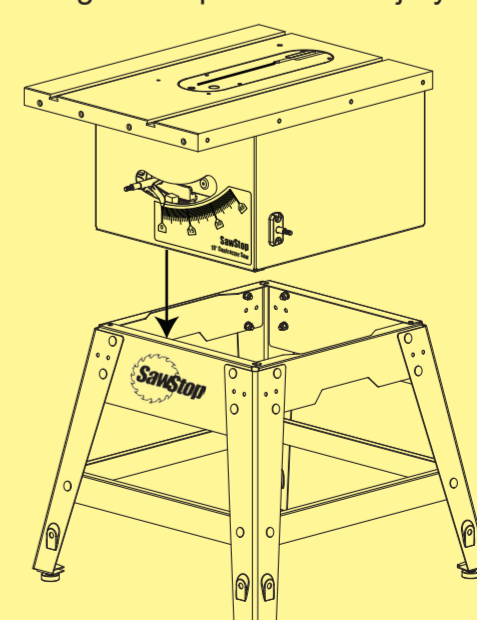

### 11

SawStop Service Department  
503-582-9934

[www.sawstop.com](http://www.sawstop.com)

© SawStop, LLC

Flip to  
Other  
Side





# Assembling Your SawStop Contractor Saw

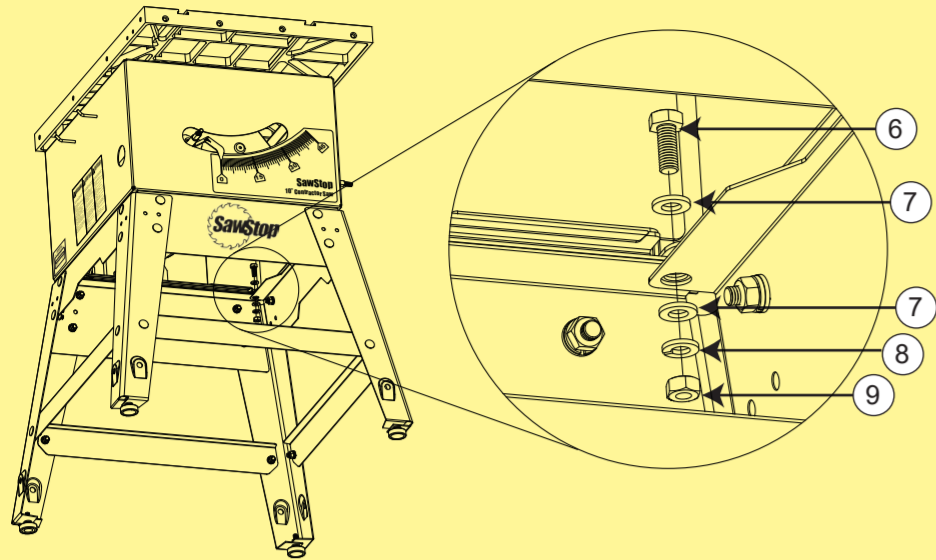

**12** • Mount the cabinet to the stand using four M8 x 20 hex screws (6), eight M8 washers (7), four M8 lock washers (8), and four M8 hex nuts (9). Insert the hex screws down through the mounting holes in the bottom corners of the saw and the top corners of the stand, and thread the hex nuts on from the bottom. Make sure to place a washer between the screw head and the saw and to place a washer and lock washer above each nut with the lock washer next to the nut, as shown. Fully tighten all of the nuts using two 13 mm wrenches.

**13** • Remove the plastic covering from the cast iron table top and remove the yellow label from the top of the table insert. Wipe the oil off the table top with a soft, clean cloth. The table top is shipped with a coating of oil to prevent the cast iron from rusting.

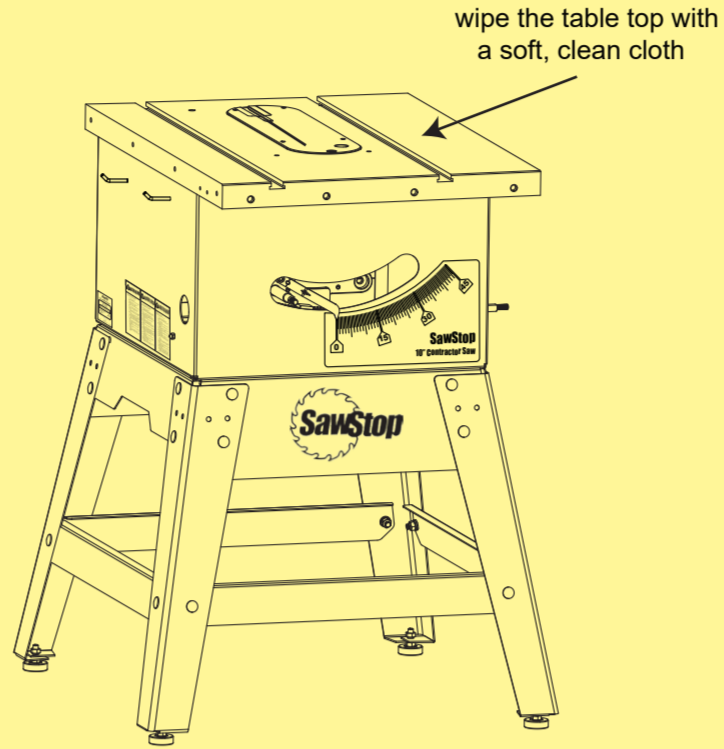

**14** • Place a level across the table top and adjust the four feet of the stand by turning the lower hex nuts until the table top is level (you may need to loosen the upper hex nuts). When the saw is level, tighten each of the foot of the upper hex nuts with a 13 mm wrench while holding the foot against rotation.

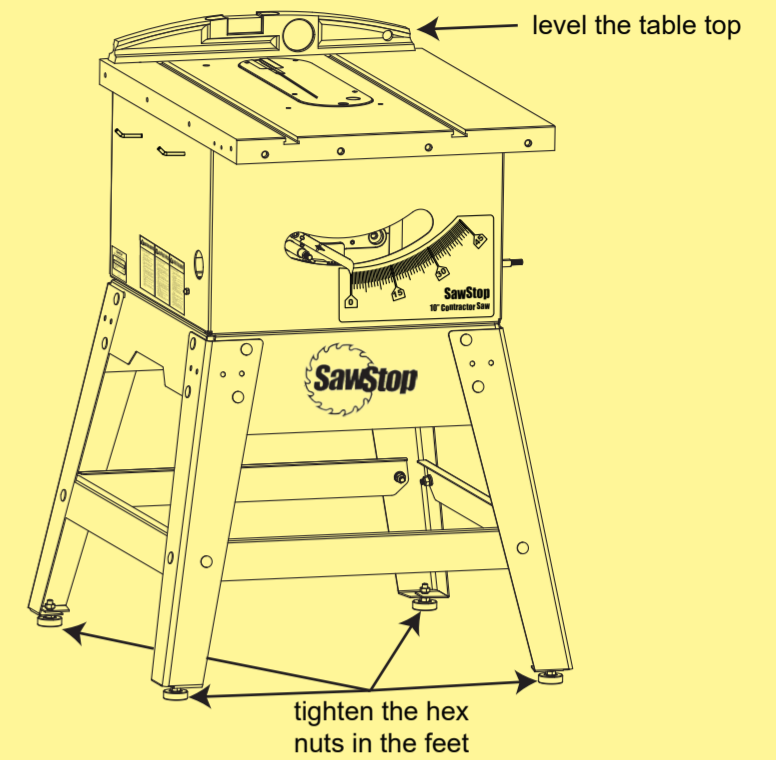

## Installing the Elevation Handwheel

**15** • Open the elevation handwheel package and remove the 2 5/8 inch long plastic spacer tube. Slide the tube as far as possible onto the elevation control shaft that extends out from the front of the saw. Next, slide the handwheel onto the same shaft. Finally, thread the elevation lock knob onto the shaft.

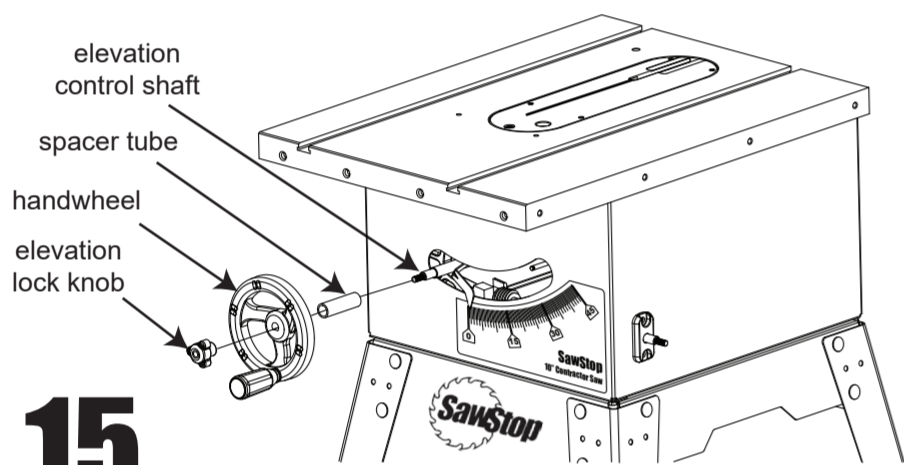

## Installing the Tilt Handwheel

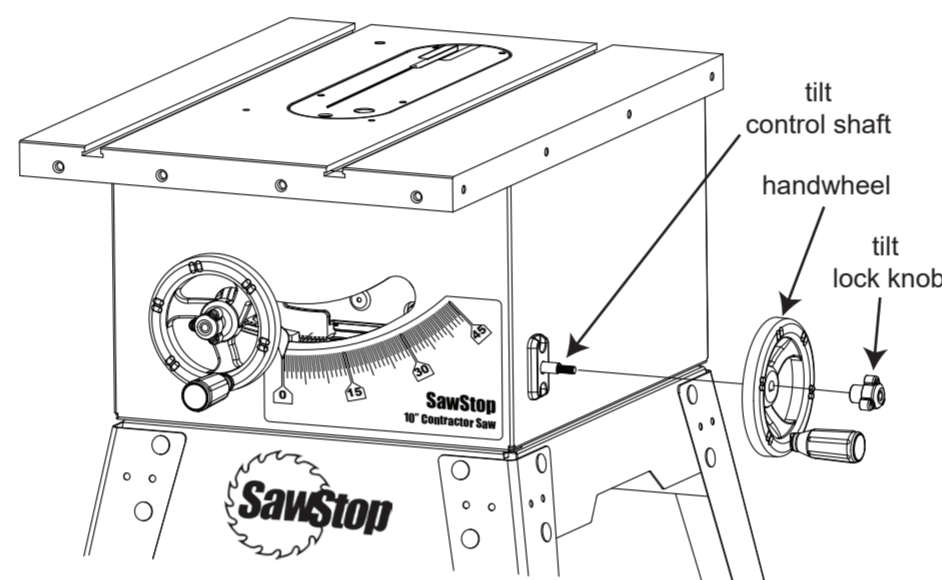

**16** • Open the blade tilt package and slide the handwheel onto the tilt control shaft and then thread the tilt lock knob onto the shaft.

## Installing the Motor and Belt Guard

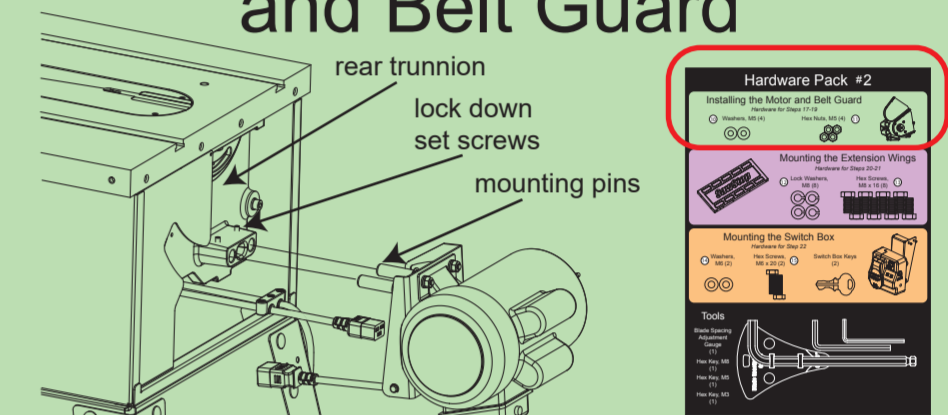

**17** • Locate the motor, the motor belt, the belt guard, and hardware pack #2. All of the hardware needed to install the motor and belt guard is located in the area with the green background on hardware pack #2. Attach the motor to the saw by sliding the motor mounting pins into the corresponding holes in the rear trunnion. Make sure the pins slide all the way into the holes. Use the 3 mm hex key included with hardware pack #2 to tighten the two lock down set screws to hold the motor in place.

**18** • Align the four holes in the belt guard with the four screws on the pulley side of the motor. Use four M5 washers (10) and four M5 hex nuts (11) from the hardware pack to mount the belt guard to the pulley side of the motor. Use an 8 mm socket to tighten the hex nuts.

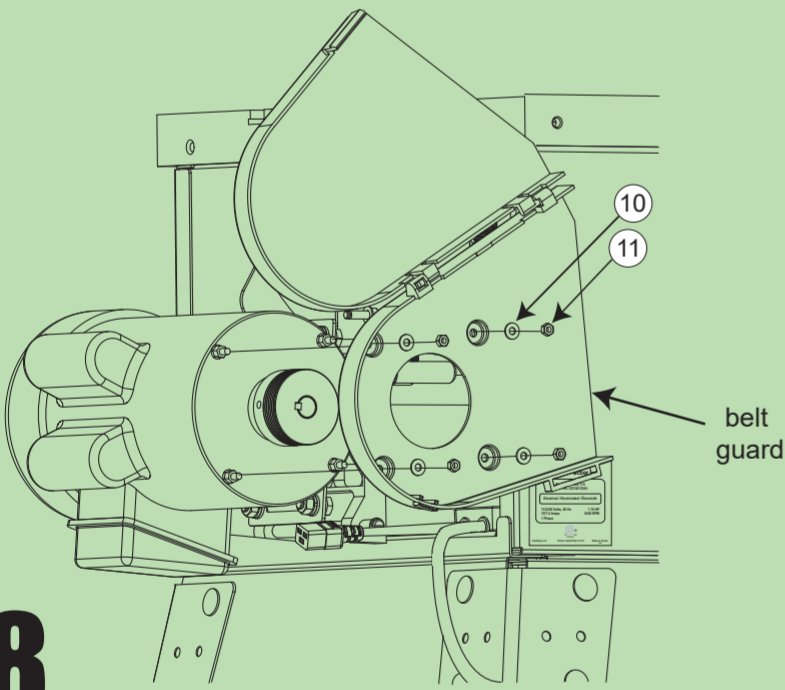

**19** • Install the motor belt by first placing the belt over the arbor pulley and then lifting the motor upward and placing the other end of the belt over the motor pulley. Release the motor when the belt is in place so that the weight of the motor puts tension on the belt. Rotate the belt by hand to make sure the ribs on the belt are aligned with the grooves on both pulleys. Note: The tilt angle of the saw can be increased to provide more access to the arbor pulley.

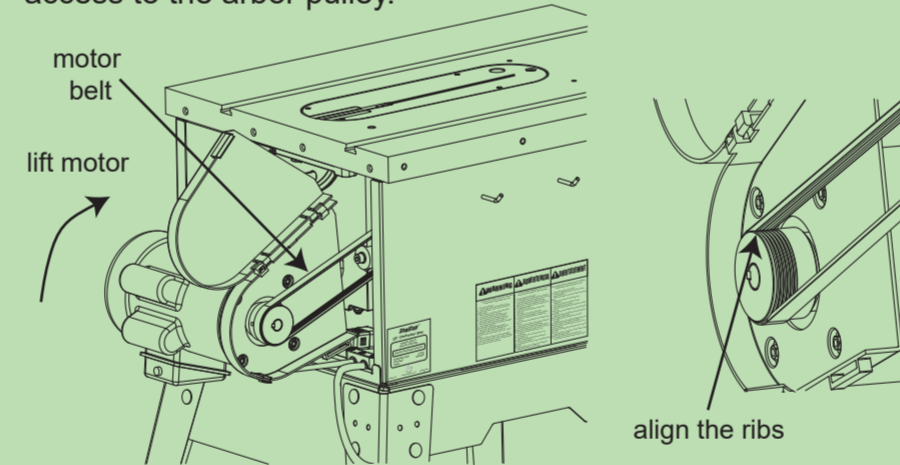

**20** • Connect the short electrical cord extending from the rear of the cabinet to the matching plug extending from the motor. Make sure the plugs are connected below the motor.

## Mounting the Extension Wings

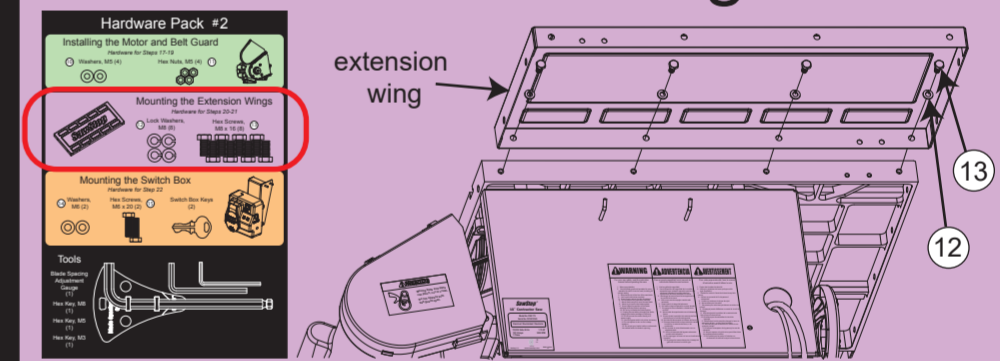

**20** • The hardware required to mount the extension wings to the cast iron table top is located in the area with the purple background on hardware pack #2. Position one of the extension wings next to the left side of the cast iron table and align the holes in the side of the wing with the four threaded holes on the side of the table. It doesn't matter which direction the SawStop lettering on the top of the extension wing faces. Mount the left extension wing with four M8 lock washers (12) and four M8 x 16 hex screws (13), but do not tighten. Repeat the same procedure to mount the other extension wing to the right side of the table.

**21** • Use a straight-edge to level the extension wings with the cast iron table top and tighten all of the M8 x 16 hex screws with a 13 mm wrench.

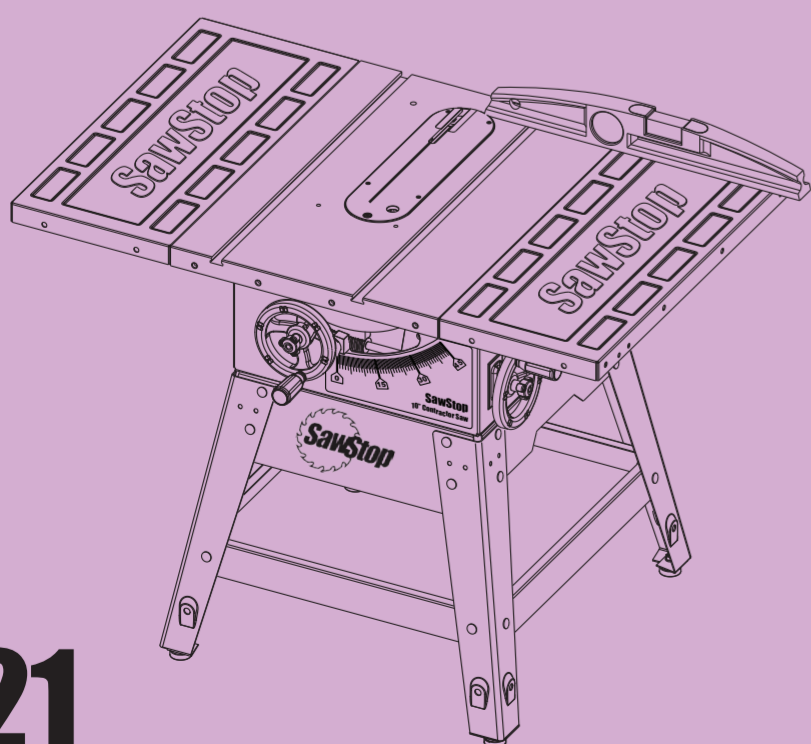

## Mounting the Switch Box

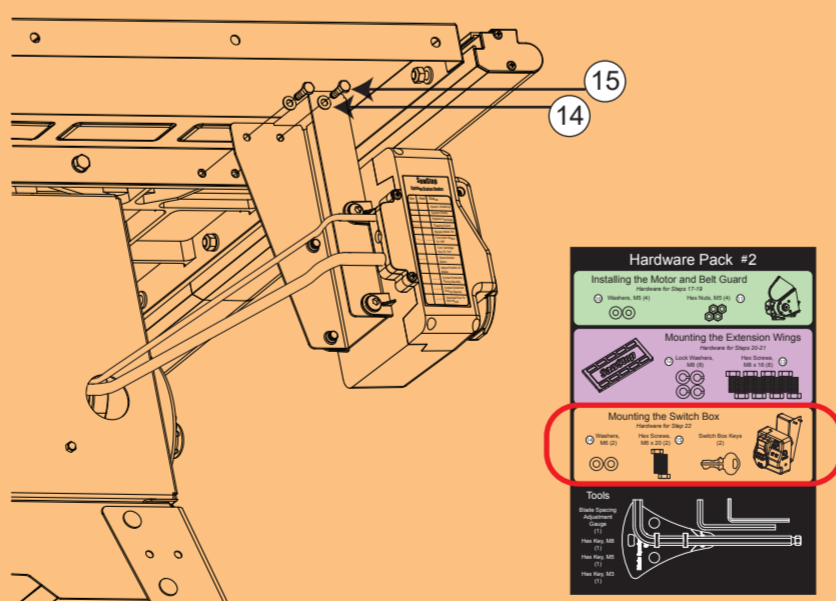

**22** • The hardware required to mount the switch box to the cast iron table top is located in the area with the orange background on hardware pack #2. Use two M6 washers (14) and two M6 x 20 hex screws (15) to mount the switch box under the left extension wing. Tighten the screws with a 10 mm wrench.

**Congratulations, your saw is now assembled.**

## Installing a Rip Fence

• You must install a rip fence prior to using the saw. The SawStop® Premium Fence and the SawStop® T-Glide™ Fence System are both designed specifically for your saw. More information about those fence systems is available in the owner's manual included with your saw. Refer to the manual accompanying your rip fence for instructions on how to install the fence.

## Other Accessories

• You can now assemble and attach optional accessories such as a mobile base and outfeed table. Visit SawStop.com or see the owner's manual included with your saw for more information about available accessories.

SawStop Service Department  
503-582-9934

www.sawstop.com

© SawStop, LLC